

VISION T EMBASE

LED Tunnel Marker with waterproof plinth IP67 for the safety marking of road and motorway tunnels. These LED Markers with a junction box indicate the safety distance to be respected by motorists.

APPLICATION

- Tunnel marking

VISION T EMBASE

Technical data	VISION T EMBASE 24 Vcc/ca	VISION T EMBASE 48 Vcc/ca	VISION T EMBASE 230Vca
Dimensions	L 153,5 x l 125 x H 89 mm		
Number of Power LEDs	2 x 12		
Power	0,7W	1,5W	1W
Body materials	UV resistant polycarbonate body 850°C M1		
LED Color	Blue Amber		
Service life	150 000 hours		
Electrical class	Class III	Class III	Class II
Connection	CR1C1 cable 2x1.5mm ² custom length (up to 20m) optional		
IK	IK10		
IP	IP67		
Fixation	4 screw slots		
Connector	Optional IP68 watertight bypass connector		
Support	Surface mounted 2/4 screws (not supplied)		
Compliance	CE 605598		
Glow wire test	850°C M1 Zero halogens		
Warranty	3 years		
Place of manufacture	France		

Photometric data +/- 10%, the manufacturer reserves the right to modify the characteristics without prior notice.

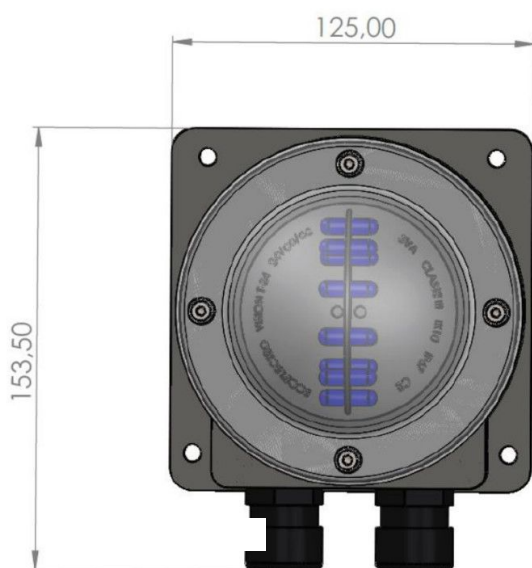

Hauteur: 89mm